Solar ABCs Efforts For Training Code Officials

Presented by

Bill Brooks, PE

Brooks Engineering

Panel Lead: Code Official Panel, Solar ABCs



Code Official Training

- The focus has been to help train electrical inspectors and building officials tasked with the plan checking and inspection of PV systems.
- John Wiles of New Mexico State University writes articles for IAEI Journal and Home Power Magazine.
- Mr. Wiles also provides training of Code Officials.
- Bill Brooks also provides training of Code Officials.
- A calendar of training events is found on www.solarabcs.org

How to get Code Official Training in your area

- Training sessions can be arranged when a sufficient number of code officials can be assembled for a detailed educational session.
- Training sessions can be provided for building and electrical code officials or fire officials for 4 to 8 hours of training with 40 or more participants.
- Local financial and logistical support is very helpful in being able to provide the maximum amount of training with limited resources.
- A calendar of training events is found on www.solarabcs.org

*Expedited Permit Process
for Small-Scale PV Systems*

Final Version Coming Soon
to a URL near you:

www.solarabcs.org

www.irecusa.org

www.BrookSolar.com



Required Information for Permit

- Site plan showing location of major components on the property. This drawing need not be exactly to scale, but it should represent relative location of components at site (see supplied example site plan). PV arrays on dwellings with a 3' perimeter space at ridge and sides do not need fire service approval.
- Electrical diagram showing PV array configuration, wiring system, overcurrent protection, inverter, disconnects, required signs, and ac connection to building (see supplied standard electrical diagram).
- Specification sheets and installation manuals (if available) for all manufactured components including, but not limited to, PV modules, inverter(s), combiner box, disconnects, and mounting system.



Step 1: Structural Review of PV Array Mounting System

- Is the array to be mounted on a defined, permitted roof structure? Yes/No
(structure meets modern codes)
- *If No due to non-compliant roof or ground mount, submit completed worksheet for roof structure WKS1.*

Roof Information:

- Is the roofing type lightweight (Yes = composition, lightweight masonry, metal, etc...)_____
 - *If No, submit completed worksheet for roof structure WKS1 (No = heavy masonry, slate, etc...).*
- Does the roof have a single roof covering? Yes/No
 - *If No, submit completed worksheet for roof structure WKS1.*
- Provide method and type of weatherproofing roof penetrations (e.g. flashing, caulk)._____



Mounting System Information:

- The mounting structure is an engineered product designed to mount PV modules?
Yes/No
 - *If No, provide details of structural attachment certified by a design professional.*
- For manufactured mounting systems, fill out information on the mounting system below:

Mounting System Information:

- a) Mounting System Manufacturer _____ Product Name and Model# _____
- b) Total Weight of PV Modules and Rails _____ lbs
- c) Total Number of Attachment Points _____
- d) Weight per Attachment Point ($b \div c$) _____ lbs (if greater than 45 lbs, see WKS1)
- e) Maximum Spacing Between Attachment Points on a Rail _____ inches (see product manual for maximum spacing allowed based on maximum design wind speed)
- f) Total Surface Area of PV Modules (square feet) _____ ft²
- g) Distributed Weight of PV Module on Roof ($b \div f$) _____ lbs/ft²
 - *If distributed weight of the PV system is greater than 5 lbs/ft², see WKS1.*

Step 2: Electrical Review of PV System (Calculations for Electrical Diagram)

- In order for a PV system to be considered for an expedited permit process, the following must apply:
 1. PV modules, utility-interactive inverters, and combiner boxes are identified for use in PV systems.
 2. The PV array is composed of 4 series strings or less, and $15 \text{ kW}_{\text{STC}}$ or less.
 3. The Inverter has a continuous power output 13,440 Watts or less
 4. The ac interconnection point is on the load side of service disconnecting means (690.64(B)).
 5. The electrical diagram (E1.1) can be used to accurately represent the PV system.

Site Diagram

- Drawing does not need to be to scale, but it should basically show where the major components are located.
- If array is ground mounted, it should show that it conforms with allowable setbacks.

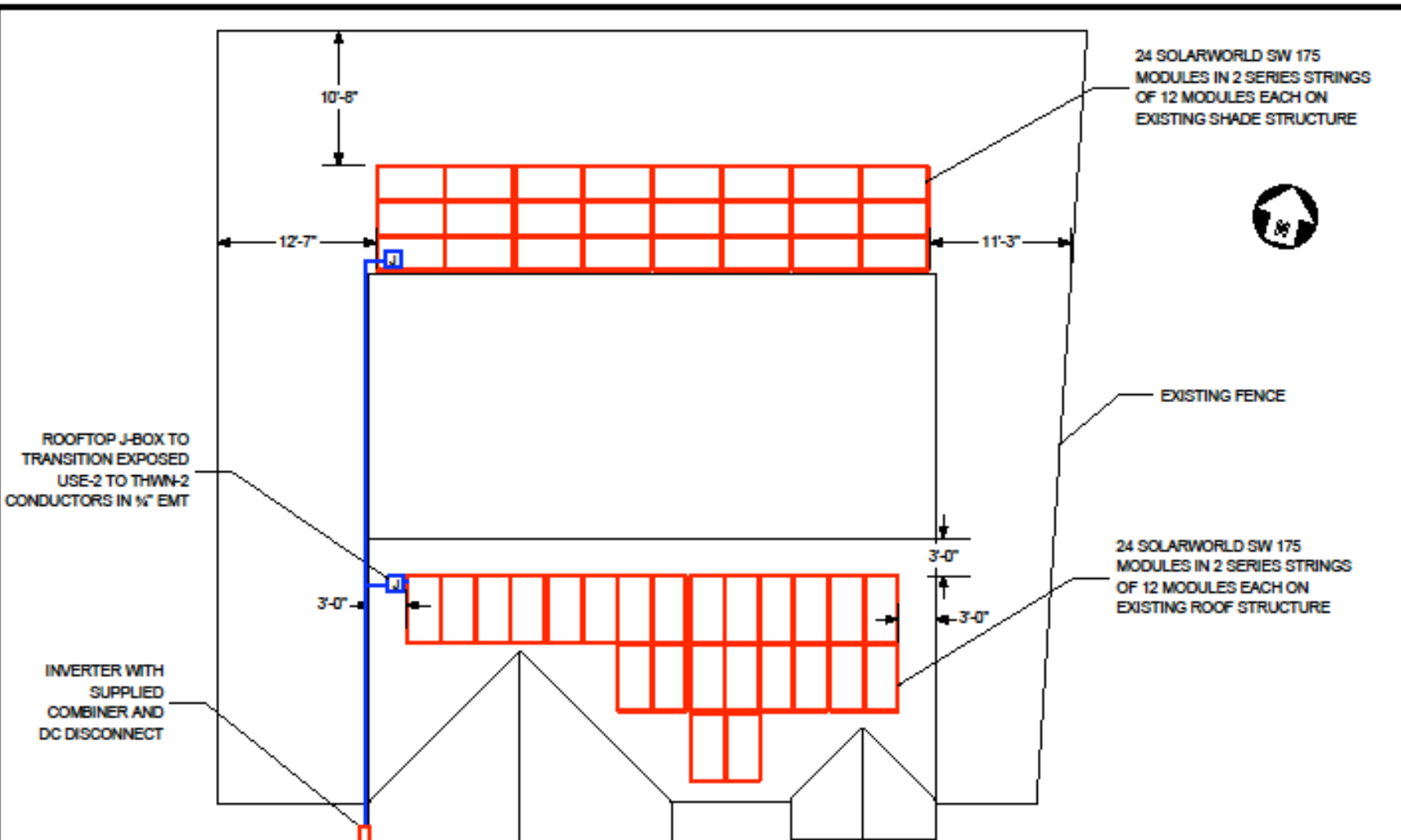

ROOFTOP J-BOX TO
TRANSITION EXPOSED
USE-2 TO THWN-2
CONDUCTORS IN 1/2" EMT

INVERTER WITH
SUPPLIED
COMBINER AND
DC DISCONNECT

EXISTING ALL-IN-ONE
SERVICE EQUIPMENT
WITH 40-AMP PV
BREAKER AS AC
DISCONNECT

24 SOLARWORLD SW 175
MODULES IN 2 SERIES STRINGS
OF 12 MODULES EACH ON
EXISTING SHADE STRUCTURE

EXISTING FENCE

24 SOLARWORLD SW 175
MODULES IN 2 SERIES STRINGS
OF 12 MODULES EACH ON
EXISTING ROOF STRUCTURE



Contractor Name,
Address and Phone:

Bill and Ted's Solar
456 Industrial Drive
San Jose, CA
408-555-1212

Site Plan
for Small-Scale, Single-Phase PV Systems
Site Name: Joe and Jane Homeowner
Site Address: 123 Sunnyside St., San Jose, CA
System AC Size: 6.9 kW Solar Array

Drawn By: Bill
Checked By: Ted

SIZE	FSCM NO	DWG NO	REV
		S1.1	0
SCALE	NTS	Date:	SHEET

One-line Diagram

- Should have sufficient detail to call out the electrical components, the wire types and sizes, number of conductors, and conduit type and size where needed.
- Should include information about PV modules and inverter(s).
- Should include information about utility disconnecting means (required by many utilities).

EQUIPMENT SCHEDULE			
TAG	DESCRIPTION	PART NUMBER	NOTES
1	SOLAR PV MODULE		
2	PV ARRAY		
3	J-BOX (IF USED)		
4	COMBINER (IF USED)		
5	DC DISCONNECT		
6	DC/AC INVERTER		
7	GEN METER (IF USED)		
8	AC DISCONNECT (IF USED)		
9	SERVICE PANEL		VAC, A MAIN, A BUS, A INVERTER OCPD (SEE NOTE 5 FOR INVERTER OCPDs, ALSO SEE GUIDE SECTION 9)

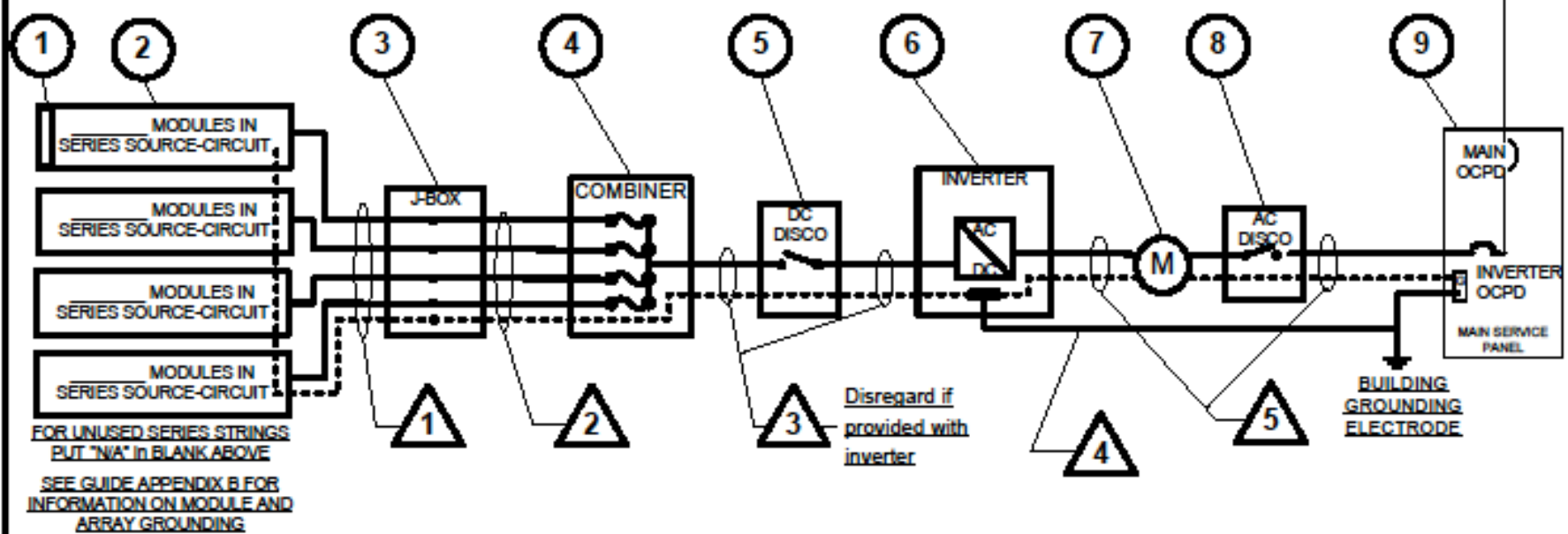

CONDUIT AND CONDUCTOR SCHEDULE					
TAG	DESCRIPTION OR CONDUCTOR TYPE	COND. GAUGE	NUMBER OF CONDUCTORS	CONDUIT TYPE	CONDUIT SIZE
1	USE-2 <input type="checkbox"/> or PV WIRE <input type="checkbox"/> BARE COPPER EQ. GRD. COND. (EGC)			N/A	N/A
2	THWN-2 <input type="checkbox"/> or XHHW-2 <input type="checkbox"/> or RHW-2 <input type="checkbox"/>				
3	THWN-2 <input type="checkbox"/> or XHHW-2 <input type="checkbox"/> or RHW-2 <input type="checkbox"/> INSULATED EGC				
4	DC GROUNDING ELECTRODE COND.				
5	THWN-2 <input type="checkbox"/> or XHHW-2 <input type="checkbox"/> or RHW-2 <input type="checkbox"/> INSULATED EGC				

Contractor Name, Address and Phone:

Drawn By: _____
Checked By: _____

One-Line Standard Electrical Diagram for Small-Scale, Single-Phase PV Systems

Site Name: _____
Site Address: _____
System AC Size: _____

SIZE	FSCM NO	DWG NO	REV
SCALE	NTS	Date:	Sheet

PV MODULE RATINGS @ STC (Guide Section 5)

MODULE MAKE	
MODULE MODEL	
MAX POWER-POINT CURRENT (I_{MP})	A
MAX POWER-POINT VOLTAGE (V_{MP})	V
OPEN-CIRCUIT VOLTAGE (V_{OC})	V
SHORT-CIRCUIT CURRENT (I_{SC})	A
MAX SERIES FUSE (OCPD)	A
MAXIMUM POWER (P_{MAX})	W
MAX VOLTAGE (TYP 600V _{DC})	V
VOC TEMP COEFF (mV/°C <input type="checkbox"/> or %/°C <input type="checkbox"/>)	
IF COEFF SUPPLIED, CIRCLE UNITS	

NOTES FOR ALL DRAWINGS:

OCPD - OVERCURRENT PROTECTION DEVICE
 NATIONAL ELECTRICAL CODE® REFERENCES SHOWN AS (NEC XXX.XX)

INVERTER RATINGS (Guide Section 4)

INVERTER MAKE	
INVERTER MODEL	
MAX DC VOLT RATING	V
MAX POWER @ 40°C	W
NOMINAL AC VOLTAGE	V
MAX AC CURRENT	A
MAX OCPD RATING	A

SIGNS—SEE GUIDE SECTION 7

SIGN FOR DC DISCONNECT	
PHOTOVOLTAIC POWER SOURCE	
RATED MPP CURRENT	A
RATED MPP VOLTAGE	V
MAX SYSTEM VOLTAGE	V
MAX CIRCUIT CURRENT	A
WARNING: ELECTRICAL SHOCK HAZARD—LINE AND LOAD MAY BE ENERGIZED IN OPEN POSITION	
SIGN FOR INVERTER OCPD AND AC DISCONNECT (IF USED)	
SOLAR PV SYSTEM AC POINT OF CONNECTION	
AC OUTPUT CURRENT	A
NOMINAL AC VOLTAGE	V
THIS PANEL FED BY MULTIPLE SOURCES (UTILITY AND SOLAR)	

NOTES FOR ARRAY CIRCUIT WIRING (Guide Section 6 and 8 and Appendix D):

- 1.) LOWEST EXPECT AMBIENT TEMPERATURE BASED ON ASHRAE MINIMUM MEAN EXTREME DRY BULB TEMPERATURE FOR ASHRAE LOCATION MOST SIMILAR TO INSTALLATION LOCATION. LOWEST EXPECTED AMBIENT TEMP _____ °C
- 2.) HIGHEST CONTINUOUS AMBIENT TEMPERATURE BASED ON ASHRAE HIGHEST MONTH 2% DRY BULB TEMPERATURE FOR ASHRAE LOCATION MOST SIMILAR TO INSTALLATION LOCATION. HIGHEST CONTINUOUS TEMPERATURE _____ °C
- 2.) 2005 ASHRAE FUNDAMENTALS 2% DESIGN TEMPERATURES DO NOT EXCEED 47°C IN THE UNITED STATES (PALM SPRINGS, CA IS 44.1°C). FOR LESS THAN 9 CURRENT-CARRYING CONDUCTORS IN ROOF-MOUNTED SUNLIT CONDUIT AT LEAST 0.5" ABOVE ROOF AND USING THE OUTDOOR DESIGN TEMPERATURE OF 47°C OR LESS (ALL OF UNITED STATES).
 - a) 12 AWG, 90°C CONDUCTORS ARE GENERALLY ACCEPTABLE FOR MODULES WITH I_{sc} OF 7.68 AMPS OR LESS WHEN PROTECTED BY A 12-AMP OR SMALLER FUSE.
 - b) 10 AWG, 90°C CONDUCTORS ARE GENERALLY ACCEPTABLE FOR MODULES WITH I_{sc} OF 9.6 AMPS OR LESS WHEN PROTECTED BY A 15-AMP OR SMALLER FUSE.

NOTES FOR INVERTER CIRCUITS (Guide Section 8 and 9):

- 1) IF UTILITY REQUIRES A VISIBLE-BREAK SWITCH, DOES THIS SWITCH MEET THE REQUIREMENT? YES NO N/A
- 2) IF GENERATION METER REQUIRED, DOES THIS METER SOCKET MEET THE REQUIREMENT? YES NO N/A
- 3) SIZE PHOTOVOLTAIC POWER SOURCE (DC) CONDUCTORS BASED ON MAX CURRENT ON NEC 690.53 SIGN OR OCPD RATING AT DISCONNECT
- 4) SIZE INVERTER OUTPUT CIRCUIT (AC) CONDUCTORS ACCORDING TO INVERTER OCPD AMPERE RATING. (See Guide Section 9)
- 5) TOTAL OF _____ INVERTER OCPD(S), ONE FOR EACH INVERTER, DOES TOTAL SUPPLY BREAKERS COMPLY WITH 120% BUSBAR EXCEPTION IN 690.64(B)(2)(a)? YES NO

Contractor Name, Address and Phone: _____ _____ _____	Notes for One-Line Standard Electrical Diagram for Single-Phase PV Systems			
	Site Name: _____ Site Address: _____ System AC Size: _____			
Drawn By: _____	SIZE	FSCM NO	DWG NO	REV
Checked By: _____	SCALE	NTS	Date:	SHEET
			E1.2	

EQUIPMENT SCHEDULE			
TAG	DESCRIPTION	PART NUMBER	NOTES
1	SOLAR PV MODULE	AS 175	AMERICAN SOLAR, QUANTITY - 48 (SEE NOTES SHEET FOR DETAILS)
2	PV ARRAY	N/A	ARRAY IS 4 STRINGS WITH 12 MODULES PER SERIES STRING
3	J-BOX (IF USED)		6"x6"x4" NEMA 4, PVC JUNCTION BOX
4	COMBINER (IF USED)	MFR-supplied	15-A MAX FUSE W/15-A FUSES, 600VDC, 4-STRING MAX
5	DC DISCONNECT	MFR-supplied	LISTED WITH INVERTER, 600VDC, 60-AMP (SEE GUIDE APPENDIX C)
6	DC/AC INVERTER	AJ-7000	7000 WATT, SINGLE PHASE (SEE NOTES SHEET FOR DETAILS)
7	GEN METER (IF USED)	FORM 2S	4-JAW, 240V CYCLOMETER REGISTER KWH METER IN 100-A BASE
8	AC DISCONNECT (IF USED)	D222NRB	240VAC, 60-AMP FUSED W/ 40-A FUSES (SEE GUIDE APPENDIX C)
9	SERVICE PANEL	SD200SL	240VAC, 200-A MAIN, 200-A BUS, 40-A INVERTER OCPD (SEE NOTE 5 FOR INVERTER OCPDs, ALSO SEE GUIDE SECTION 9)

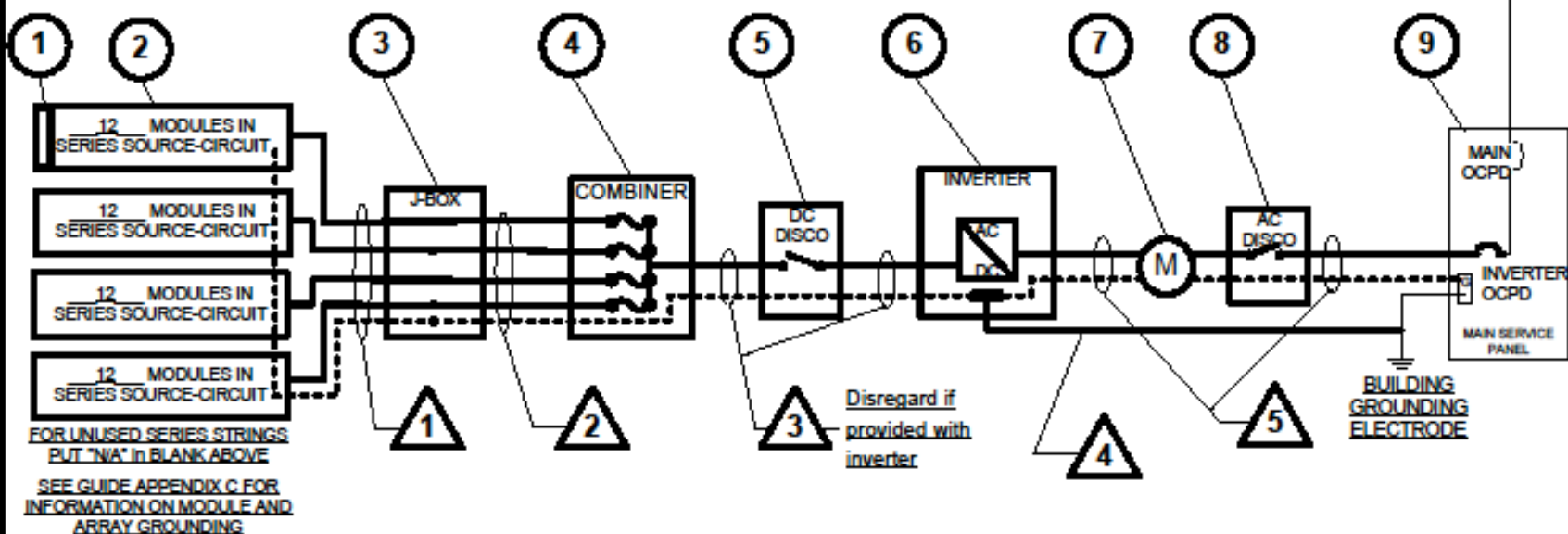

CONDUIT AND CONDUCTOR SCHEDULE					
TAG	DESCRIPTION OR CONDUCTOR TYPE	COND. GAUGE	NUMBER OF CONDUCTORS	CONDUIT TYPE	CONDUIT SIZE
1	USE-2 <input checked="" type="checkbox"/> or PV WIRE <input type="checkbox"/>	10 AWG	8 BLACK	N/A	N/A
	BARE COPPER EQ. GRD. COND. (EGC)	10 AWG	1 BARE CU	N/A	N/A
2	THWN-2 <input checked="" type="checkbox"/> or XHHW-2 <input type="checkbox"/> or RHW-2 <input type="checkbox"/>	10 AWG	4-R, 4-W, 1-G	EMT	1/2"
3	THWN-2 <input type="checkbox"/> or XHHW-2 <input type="checkbox"/> or RHW-2 <input type="checkbox"/>	N/A	N/A	N/A	N/A
	INSULATED EGC	N/A	N/A		
4	DC GROUNDING ELECTRODE COND.	6 AWG	1 BARE CU	N/A	N/A
5	THWN-2 <input checked="" type="checkbox"/> or XHHW-2 <input type="checkbox"/> or RHW-2 <input type="checkbox"/>	8 AWG	1-R, 1-B, 1-W	EMT	1/2"
	INSULATED EGC	10 AWG	1 GREEN		

Contractor Name, Address and Phone: Bill and Ted's Solar 456 Industrial Drive San Jose, CA 408-555-1212		One-Line Standard Electrical Diagram for Small-Scale, Single-Phase PV Systems Site Name: Joe and Jane Homeowner Site Address: 123 Sunnyside St., San Jose, CA System AC Size: 6.9 kW Solar Array			
Drawn By: Bill	SIZE	FSCM NO	DWG NO	REV	
Checked By: Ted	SCALE	NTS	Date:	E1.1	0
				SHEET	

PV MODULE RATINGS @ STC (Guide Section 5)

MODULE MAKE	AMERICAN SOLAR
MODULE MODEL	AS 175
MAX POWER-POINT CURRENT (I_{mp})	4.89 A
MAX POWER-POINT VOLTAGE (V_{mp})	35.8 V
OPEN-CIRCUIT VOLTAGE (V_{oc})	44.4 V
SHORT-CIRCUIT CURRENT (I_{sc})	5.3 A
MAX SERIES FUSE (OCPD)	15 A
MAXIMUM POWER (P_{max})	175 W
MAX VOLTAGE (TYP 600V _{DC})	600 V
VOC TEMP COEFF (mV/°C □ or %/°C □)	-0.33
IF COEFF SUPPLIED, CIRCLE UNITS	

NOTES FOR ALL DRAWINGS:

OCPD = OVERCURRENT PROTECTION DEVICE
 NATIONAL ELECTRICAL CODE® REFERENCES SHOWN AS (NEC XXX.XX)

INVERTER RATINGS (Guide Section 4)

INVERTER MAKE	AMERICAN INVERTER
INVERTER MODEL	AI-7000
MAX DC VOLT RATING	600 V
MAX POWER @ 40°C	7000 W
NOMINAL AC VOLTAGE	240 V
MAX AC CURRENT	29 A
MAX OCPD RATING	50 A

SIGNS-SEE GUIDE SECTION 7

SIGN FOR DC DISCONNECT

PHOTOVOLTAIC POWER SOURCE	
RATED MPP CURRENT	19.6 A
RATED MPP VOLTAGE	430 V
MAX SYSTEM VOLTAGE	577 V
MAX CIRCUIT CURRENT	25.5 A
WARNING: ELECTRICAL SHOCK HAZARD-LINE AND LOAD MAY BE ENERGIZED IN OPEN POSITION	

SIGN FOR INVERTER OCPD AND AC DISCONNECT (IF USED)

SOLAR PV SYSTEM AC POINT OF CONNECTION	
AC OUTPUT CURRENT	29 A
NOMINAL AC VOLTAGE	240 V
THIS PANEL FED BY MULTIPLE SOURCES (UTILITY AND SOLAR)	

NOTES FOR ARRAY CIRCUIT WIRING (Guide Section 6 and 8 and Appendix E):

- 1.) LOWEST EXPECT AMBIENT TEMPERATURE BASED ON ASHRAE MINIMUM MEAN EXTREME DRY BULB TEMPERATURE FOR ASHRAE LOCATION MOST SIMILAR TO INSTALLATION LOCATION. LOWEST EXPECTED AMBIENT TEMP 0 °C
- 2.) HIGHEST CONTINUOUS AMBIENT TEMPERATURE BASED ON ASHRAE HIGHEST MONTH 2% DRY BULB TEMPERATURE FOR ASHRAE LOCATION MOST SIMILAR TO INSTALLATION LOCATION. HIGHEST CONTINUOUS TEMPERATURE 34 °C
- 2.) 2005 ASHRAE FUNDAMENTALS 2% DESIGN TEMPERATURES DO NOT EXCEED 47°C IN THE UNITED STATES (PALM SPRINGS, CA IS 44.1°C). FOR LESS THAN 9 CURRENT-CARRYING CONDUCTORS IN ROOF-MOUNTED SUNLIT CONDUIT AT LEAST 0.5" ABOVE ROOF AND USING THE OUTDOOR DESIGN TEMPERATURE OF 47°C OR LESS (ALL OF UNITED STATES).
 - a) 12 AWG, 90°C CONDUCTORS ARE GENERALLY ACCEPTABLE FOR MODULES WITH I_{sc} OF 7.68 AMPS OR LESS WHEN PROTECTED BY A 12-AMP OR SMALLER FUSE.
 - b) 10 AWG, 90°C CONDUCTORS ARE GENERALLY ACCEPTABLE FOR MODULES WITH I_{sc} OF 9.6 AMPS OR LESS WHEN PROTECTED BY A 15-AMP OR SMALLER FUSE.

NOTES FOR INVERTER CIRCUITS (Guide Section 8 and 9):

- 1) IF UTILITY REQUIRES A VISIBLE-BREAK SWITCH, DOES THIS SWITCH MEET THE REQUIREMENT? YES NO N/A
- 2) IF GENERATION METER REQUIRED, DOES THIS METER SOCKET MEET THE REQUIREMENT? YES NO N/A
- 3) SIZE PHOTOVOLTAIC POWER SOURCE (DC) CONDUCTORS BASED ON MAX CURRENT ON NEC 690.53 SIGN OR OCPD RATING AT DISCONNECT
- 4) SIZE INVERTER OUTPUT CIRCUIT (AC) CONDUCTORS ACCORDING TO INVERTER OCPD AMPERE RATING. (See Guide Section 9)
- 5) TOTAL OF 1 INVERTER OCPD(S), ONE FOR EACH INVERTER, DOES TOTAL SUPPLY BREAKERS COMPLY WITH 120% BUSBAR EXCEPTION IN 690.54(B)(2)(a)? YES NO

Contractor Name, Address and Phone:		Notes for One-Line Standard Electrical Diagram for Single-Phase PV Systems		
Bill and Ted's Solar 455 Industrial Drive San Jose, CA 408-555-1212		Site Name: Joe and Jane Homeowner Site Address: 123 Sunnyside St., San Jose, CA System AC Size: 6.9 kW Solar Array		
Drawn By: Bill	SIZE	FSCM NO	DWG NO	REV
Checked By: Ted	SCALE	NTS	Date:	0
			E1.2	
			8-467	

Major Component and Array Electrical Information

- Inverter information
- Module information
- Combiner Box
- Disconnects



Inverter information

- Model number and manufacturer's "cut sheets" for the specific model.
- Listing—is the inverter listed to UL1741 and labeled "Utility-Interactive"? For a current list of compliant inverters, visit the California Solar Program website. www.gosolarcalifornia.com
- Maximum continuous output power at 40°C



Module information

- Manufacturer's "cut sheets" for the specific model.
- Listing. The module should be listed to UL 1703. For a current list of modules that are listed to UL 1703, visit the California website.

www.gosolarcalifornia.com

- Listing label information

Typical PV Module Label

PHOTOVOLTAIC MODULE			
MODEL	KC120-1		
SER NO.	01632A1055		
DATE	2001.6		
IRRADIANCE AND CELL TEMPERATURE	1000Wm ⁻² AM 1.5 25 °C	800Wm ⁻² AM 1.5 47 °C	MAX. SYS VOLT.
			600 V
P _{max}	120 W	87 W	SERIES FUSE
V _{pmax}	16.9 V	15.2 V	
I _{pmax}	7.10 A	5.74 A	11 A
V _{oc}	21.5 V	---	MASS
I _{sc}	7.45 A	---	
 LISTED 9P82	FIELD WIRING		FIRE RATING
	STRANDED COPPER ONLY 10 ~ 14 AWG INSULATED FOR 90 °C		CLASS C



Array electrical information

- Number of modules in series
- Array operating voltage
- Array operating current
- Maximum system voltage
- Array short circuit current

